



AIR CONDITIONING



REFRIGERATION



HEATING



IN

Heavy Duty 6 & 10

CONDENSATE REMOVAL PUMP

With an impressive flow rate, these robust and reliable Heavy Duty pumps are perfect for the rapid removal of large quantities of condensate water.

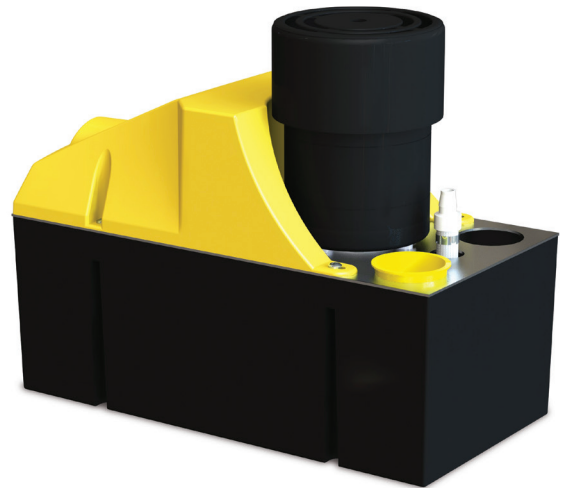

HD6: 900L/h max. flow
HD10: 1070L/h max. flow



HD6: 6m max. rec. head
(flow rate 180L/h)
HD10: 9m max. rec. head
(flow rate 100L/h)

KEY FEATURES

- High flow rate
- Non return valve
- Easy installation
- 4 litre tank capacity

SUITABILITY

- HD6: Up to 1200kW / 4m Btu/h*
- HD10: Up to 1460kW / 4.9m Btu/h*
- Humidifiers; Air handling units (AHUs)

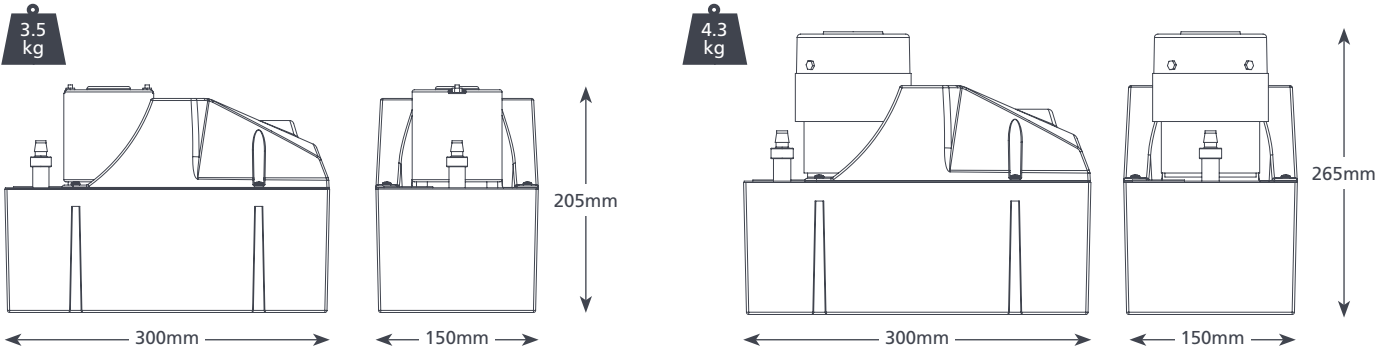

HEAVY DUTY 6 & 10 @ 230V 50Hz

Max. flow	HD6: 900L/h, HD10: 1070L/h
Max. rec. head	HD6: 6m, HD10: 9m
Tank capacity	4L
dB(A) @ 1m	HD6: 60, HD10: 64
Power supply	HD6: 230 VAC, 1.5A, 50Hz HD10: 230 VAC, 0.38A, 50Hz
Rated	HD6: Non continuous HD10: Continuous
Class	I appliance
Max. unit output	HD6: 1200kW / 4m Btu/h* HD10: 1460kW / 4.9m Btu/h*
Max. water temp	40°C / 104°F
Inlet/outlet	x2 40mm in, 10mm out
IP Protection	IP20
Safety switch	3.0A Normally closed

HEAVY DUTY 6 & 10 OPTIONS

Heavy Duty 6	FP2074/2
Heavy Duty 10	FP2066/2

* When high humidity, reduce duties by 20%

IN THE BOX

- Heavy Duty 6 or 10 pump
- 2m power cable
- Install manual

Download manual at aspenpumps.com

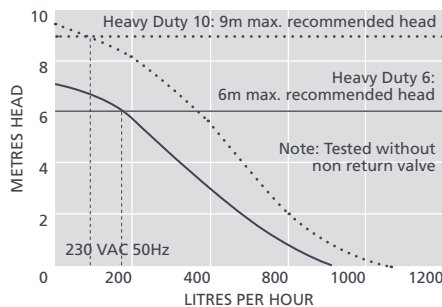

Information correct at time of going to press.



aspenpumps.com

sales.india@aspenpumps.com

reliable | silent | simple 27