



AIR CONDITIONING



REFRIGERATION



HEATING



IN

Standard

CONDENSATE REMOVAL PUMP



Operated by an air conditioning cooling signal, the Standard peristaltic sets the standard for reliability. The remote install options means minimum future maintenance disruption.



6.5L/h max. flow



12m max. head
(flow rate 6.5L/h)

KEY FEATURES

- AC cooling signal operated
- Remote install possible
- Pumps contaminated water
- Can run dry

SUITABILITY

- Up to 8.5kW / 29,000Btu/h
- High wall split systems; Ducted units; Floor standing & Chassis units
- ✓ **Perfect for...** 230V Cooling unit signal operation

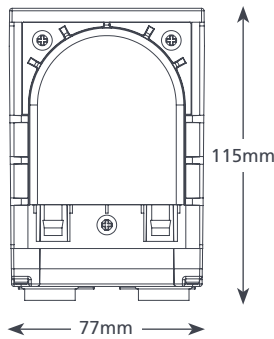
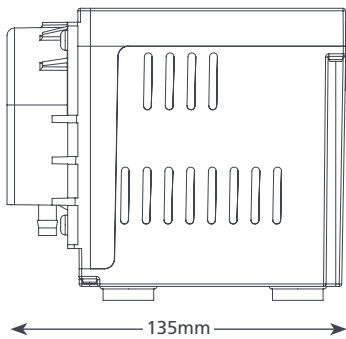

STANDARD @ 230 VAC 50Hz

Max. flow	6.5L/h @ 12m head
Max. head	12m
Max. suction lift	3m
dB(A) @ 1m	47
Power supply	230 VAC, 0.2A, 50-60Hz
Rated	Continuously
Class	I appliance
Max. unit output	8.5kW / 29,000Btu/h
Max. water temp	40°C / 104°F
Inlet/outlet	6mm ID
IP Protection	IP21
Safety switch	n/a
Thermal protection	✓
Fully potted	n/a
Self priming	✓

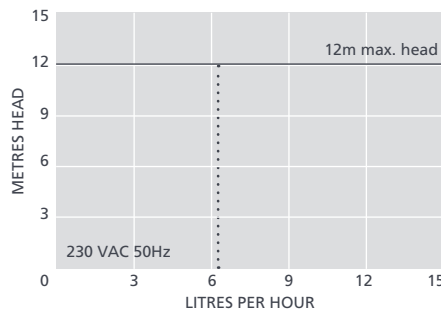

IN THE BOX

- Standard pump
- 2m Plug & play power cable
- Wall mounted bracket
- Fixing kit
- Install manual

STANDARD OPTIONS

- Standard
- FP2081/2

- 📖 Download manual at aspenspumps.com
- ▶ View install video at aspenspumps.com

Information correct at time of going to press.

