



AIR CONDITIONING



REFRIGERATION



HEATING



IN

Macerator 4L

CONDENSATE REMOVAL PUMP

Designed to collect defrost water from multiple refrigeration cabinets. The internal filter blade prevents the pumps from clogging, allowing longer intervals between maintenance visits.



780L/h max. flow



8.5m max. rec. head (flow rate 80L/h)

KEY FEATURES

- Internal filter blade
- High flow & head
- Hi-level safety switch

SUITABILITY

- Single and multiple refrigeration units
- ✓ **Perfect for...** handling food waste that may pass through the pump

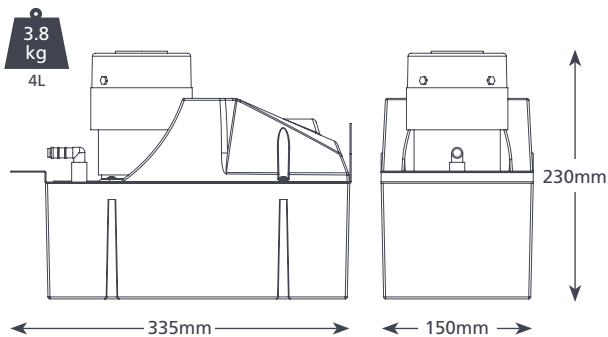

MACERATOR 4L & 10L @ 230 VAC 50Hz	
Max. flow	780L/h @ 0m head
Max. rec. head	8.5m
Tank capacity	4L
dB(A) @ 1m	64
Power supply	230 VAC, 0.38A, 50/60Hz
Rated	Non continuous
Class	I appliance
Max. unit output	n/a
Max. water temp	40°C / 104°F
Inlet/outlet	x2 40 & 55mm in, 10mm out
Additional inlet	3/4" in tank (10L only)
IP Protection	4L & 10L: IP21
Safety switch	4.0A Normally closed
Thermal protection	✓
Self priming	n/a

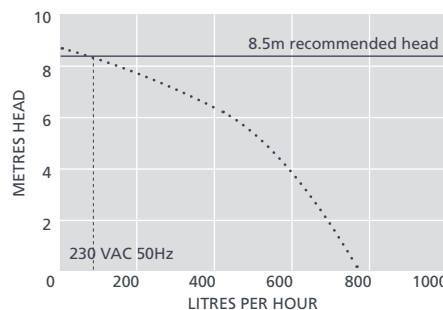

IN THE BOX
 Macerator 4L or 10L pump (including hard wired 2m power cable) • Install manual

MACERATOR 4L & 10L OPTIONS

Macerator 4L

FP2305

Download manual at aspenspumps.com

Information correct at time of going to press.