



AIR CONDITIONING



REFRIGERATION



HEATING



ASPEN PUMPS INC



Maxi Lime

CONDENSATE REMOVAL PUMP

Designed for larger units & humid environments. The Maxi Lime elbow pump gives you supreme power when needed.



9 US Gal/h / 35L/h max. flow



39ft / 12m max. rec. head (flow rate 2.6 US Gal/h / 10L/h)



35dB(A)

KEY FEATURES

- Sits in trunking elbow
- Left or right install
- Easy access for servicing

SUITABILITY

- Up to 12ton / 157,000Btu/h
- Large commercial AC units; Ductless mini split systems



CSI compliant



16.5 oz



0.47 kg†

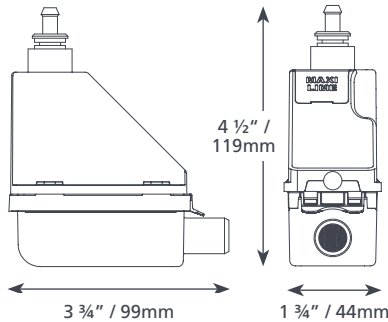

MAXI LIME SPECIFICATIONS @ 230 VAC 60Hz

Max. flow @ 0 head	9 US Gal/h / 35L/h
Max. rec. head	39ft / 12m
Max. suction lift	n/a
dB(A) @ 3ft / 1m	35
Power supply	230 VAC, 0.1A, 16W, 50/60Hz
Rated	Non continuous
Class	II appliance
Max. unit output	12ton / 157,000Btu/h
Max. water temp	104°F / 40°C
Discharge tube	1/4" / 6mm ID
IP Protection	IP24
Safety switch	3.0A Normally closed
Thermal protection	✓
Fully potted	✓
Self priming	✓

MAXI LIME OPTIONS

Maxi Lime OEM 230V FP2490/RS

IN THE BOX

Maxi Lime OEM pump (inc. 29 1/2" / 750mm discharge tube with 1/4" / 6mm ID connector and 1.5m hard wired power cable)

- 19 3/4" / 500mm Lime green inlet hose
- 9/16" / 14mm ID • 1 3/8" / 40mm Vinyl breather tube
- 1/4" / 6mm ID • Anti siphon device • Drain connector kit • Inline Fuse • Fixing kit
- Install manual

Download manual at aspenspumps.com

View install video at aspenspumps.com

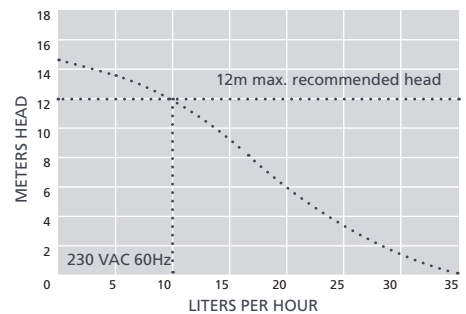
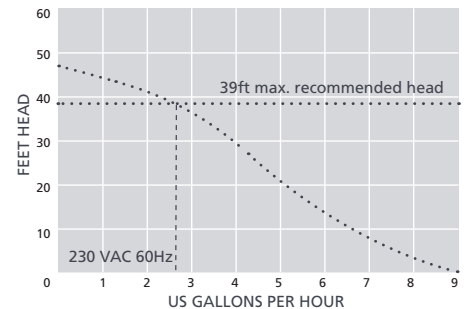

Information correct at time of going to press.



aspenspumps.com

toll free (866) 772 2111

sales@aspenspumps.com

reliable | silent | simple