

Silent+ Mini White



CONDENSATE REMOVAL PUMP

Incredibly quiet, easy to install and maintain, the Silent+ Mini White has been designed to fit either side beneath high wall indoor units. A double insulated reservoir eliminates condensation and is simple to unclip for cleaning and maintenance.

12 US Gal/h
(45L/h) max. flow

33ft / 10m max. rec.
head (flow rate 23L/h)

As low as 16dB(A)
when operating

KEY FEATURES

- Ultra quiet operation
- Extra quick to fit
- Compact & discreet
- Removable reservoir

SUITABILITY

- Up to 16kW / 54,000Btu/h
- High wall mini unit systems

✓ **Perfect for...** domestic environments where minimising audible noise is crucially important

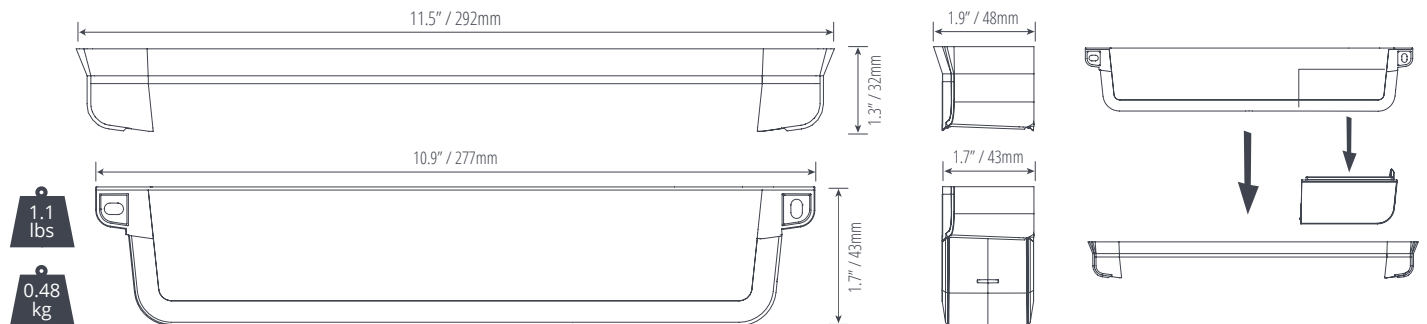

1.1 lbs
 0.48 kg

SILENT+ MINI WHITE @ Univolt 100-250 VAC 50/60Hz	
Max. flow	12 US Gal/h 45L/h @ 0m head
Max. rec. head	33ft / 10m
Min. dB(A) @ 1m	16
Power supply	0.18A, 2.1W 50/60Hz
Rated	Continuous
Class	II appliance <input type="checkbox"/>
Max. unit output	16kW / 54,000Btu/h
Max. ambient temperature	104°F / 40°C
IP Protection	IP24
Inlet o/d	5/8" (16mm) - 1" (26mm)
Outlet o/d	1/4" / Ø6mm
Safety switch	5.0 A NO & NC contacts
Thermal protection	✓
Self priming	✓

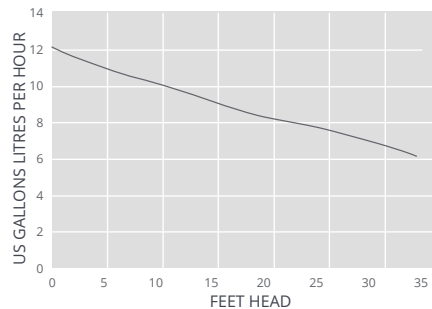

IN THE BOX
Silent+ Mini White pump (incl. hard wired 3.28ft (1m) power cable) • Fitting template • Outlet elbow • Screw caps • Spacer • Installation manual

Download manual at aspenpumps.com

SILENT+ MINI WHITE OPTIONS	
Silent+ Mini White (US)	FP3400/RS

