



ANCILLARIES

Mighty Bracket™

Mini-split installation is now a one man job!
Clips to the mounting bracket of most mini-splits.

KEY FEATURES

- Holds unit securely in place during installation – without damaging walls
- Allows single person installation
- Does not damage walls
- Ideal for most brands of mini-splits that weigh up to 45kg
- Folds for easy storage
- Includes tote bag



Mighty Bracket™
Mini-split Installation Support Tool

SPECIFICATIONS		OPTIONS		APPLICATION
Materials of construction	ABS	Description	Part No.	Hook onto mini-split mounting plate to hold mini-split unit securely in place while installing refrigerant lines, condensate line and electrical hookup.
		Mighty Bracket™	AX3010	

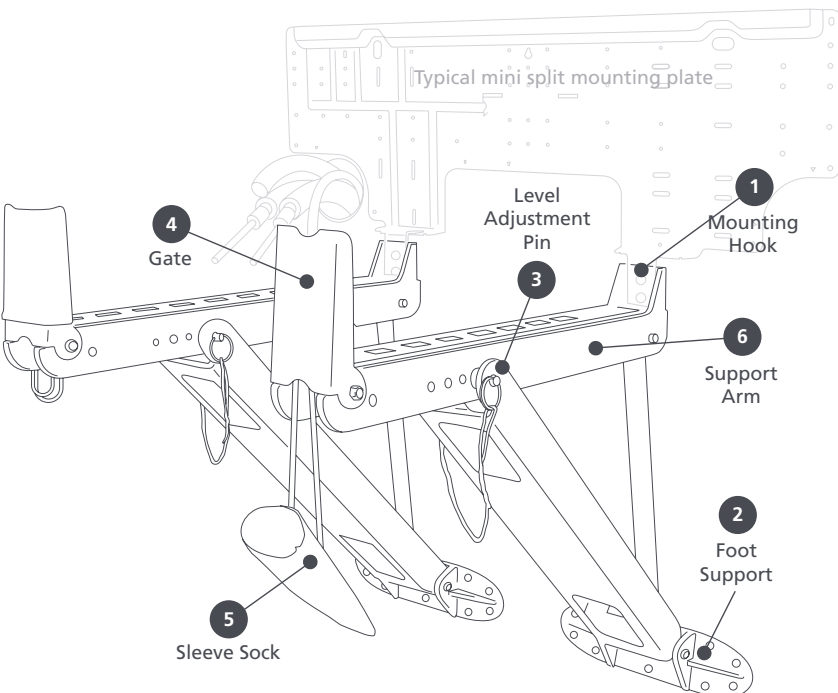

USER INSTRUCTIONS
1. Attach Mounting Hooks of Mighty Bracket to the mini-split mounting plate tabs (if no tabs are present on the mounting plate, Mighty Bracket hooks can be attached by screws threaded into the wall stud).
2. Place Foot Supports flat against the wall (if necessary to avoid potential wall scratching, place clean towel or cardboard between support foot and wall surface).
3. Position Level Adjustment Pins to make Support Arm of the brackets horizontal.
4. Position Lift Gates at the end of Support Arms to make sure the unit cannot slide off.
5. Place protective Sleeve socks over Gates to avoid scratching the unit.
6. Set unit securely onto the top of the Support Arms.
7. Connect refrigerant lines.
8. Connect condensate drain piping and electrical wiring.
9. Carefully lift and place the indoor unit onto top tabs of mounting plate.
10. While ensuring unit does not fall, carefully remove Mighty Bracket and installation is complete.

For further details please refer to our website aspenspumps.com

Information correct at time of going to press.